

0.3m (1ft) Low Profile Antennas

Microwave Antenna Specifications

Aug. 01, 2017

General Specifications



Nominal diameter	0.3m (1ft)
Polarization	Single, Vertical or Horizontal
Radio interface	Direct Mount for RFU-C type ODU
Antenna color	Gray (Pantone 1C)
Radome color	Gray (Pantone 1C)
Radome type	Hard cover
Packing type	Carton
Gross weight, kg	12±2
Packed dimensions, mm	L x W x H 500 x 450 x 320
Packing Volume, m ³	0.072

Electrical Specifications

Antenna Marketing Model	Am-1-11W-CR	Am-1-13-CR	Am-1-15-CR	Am-1-18-CR	Am-1-23-CR
PN	AN-3300-1	AN-3301-1	AN-3302-1	AN-3303-1	AN-3304-1
Frequency Band (GHz)	10.000 - 11.700	12.750 - 13.250	14.400 - 15.350	17.700 - 19.700	21.200 - 23.600
Waveguide Interface	UBR100	UBR120	UBR140	UBR220	UBR220
Gain (dBi) Low	28.7	30.8	31.9	33.6	35.2
Gain (dBi) Mid	29.4	31.0	32.1	34.1	35.7
Gain (dBi) High	30.0	31.1	32.4	34.6	36.1
3 dB Beam Width (°)	5.5	4.6	4.0	3.2	2.7
VSWR	1.30	1.30	1.30	1.30	1.30
F/B Ratio (dB)	55	57	60	62	60
XPD (dB)	30	30	30	30	30

ETSI Compliance	R1, C3	R1, C3	R2, C3	R2, C3	R3, C3
RPE Number	BL10577	BL10582	BL10583	BL10584	BL10585

Antenna Marketing Model	Am-1-26-CR	Am-1-28-CR	Am-1-32-CR	Am-1-38-CR	Am-1-42-CR
PN	AN-3305-1	AN-3306-1	AN-3307-1	AN-3308-1	AN-3309-1
Frequency Band (GHz)	24.000 - 26.500	27.500 - 29.500	31.800 - 33.400	37.000 - 40.000	40.500 - 43.500
Waveguide	UBR220	UBR320	UBR320	UBR320	UG383/U
Gain (dBi) Low	36.4	37.5	38.7	40.0	40.4
Gain (dBi) Mid	36.8	37.7	38.9	40.4	40.8
Gain (dBi) High	37.1	38.0	39.2	40.7	41.1
3 dB BW (°)	2.4	2.1	1.8	1.5	1.5
VSWR	1.30	1.30	1.30	1.30	1.30
F/B Ratio (dB)	63	63	57	58	60
XPD (dB)	30	30	30	30	30
ETSI	R4, C3	R4, C3	R5, C3B	R5, C3B	R5, C3B
RPE Number	BL10586	BL10587	BL10588	BL10589	BL10590

Mechanical Specifications

Wind Velocity Operational, km/h	250
Wind Velocity Survival Rating, km/h	320
Ice Load, mm	25
Coarse Azimuth, Adjustment, Degrees	360
Fine Azimuth Adjustment, Degrees	±15
Coarse Elevation, Degree	±10
Fine Elevation Adjustment, Degrees	±15
Mounting Pipe Diameter, mm	51 to 114
Net weight, kg	8.5±1
Feed horn, Operational Pressure, KPa	50
Operational Temperature, °C	-45 to +60
Storage Temperature, °C	-55 to +70
Adjustment Struts	None
Fixed Support Struts	None
Humidity	100%
Rain Intensity, mm/min	15

Solar Radiation, W/m ²	1120
Electrical properties	ETSI EN 302 217-4-2
Vibration	ETSI 300 019-2-4 V2.2.2 (2003-04) T4.1E.
RoHS2011/65/EU	Compliant

Outline Dimensions

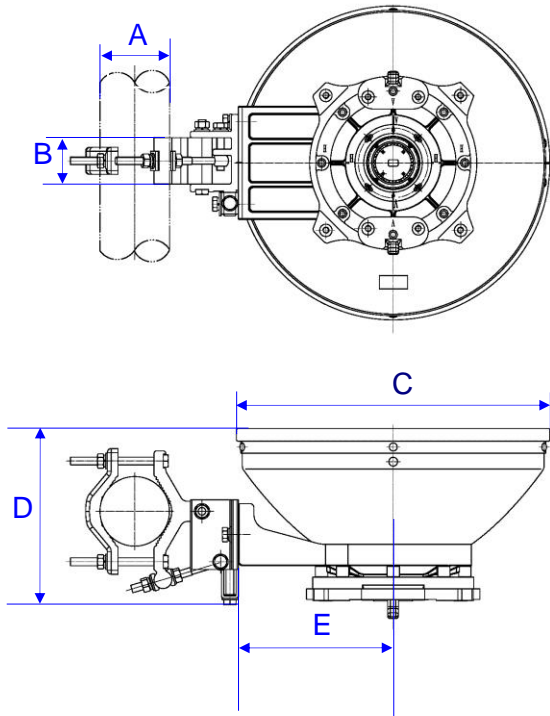

Antenna dimensions, mm	
A	51 to 114
B	60
C	405
D	228
E	200

Wind Forces

The axial, side and twisting moment forces stated are maximum loads applied to the tower by the antenna at a survival wind speed of 320km/h (89m/s). They are, in every case, the result of wind from the most critical direction for each parameter. The individual maximums may not occur simultaneously. All forces are referenced to the antenna mounting pipe.

Axial Force (F_A), N	780
Side Force (F_S), N	380
Twisting Moment (M_T), N·m	300
Angle α for M_T Max, Degree	-10

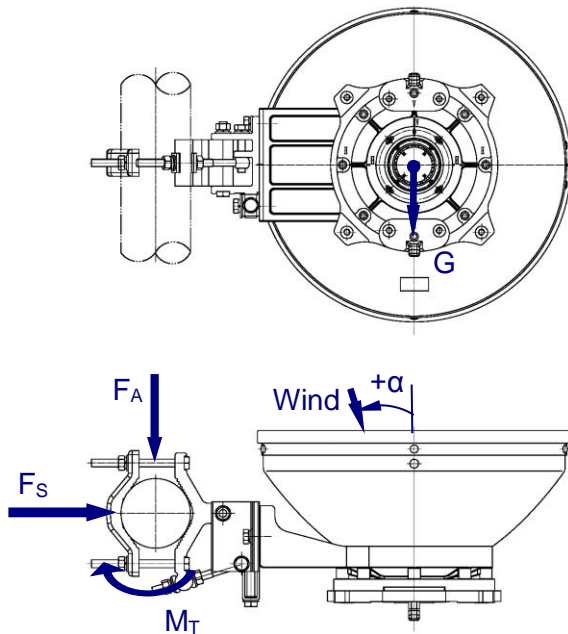

Radiation Pattern Envelope

Co-polar and X-polar response are represented for both horizontal and vertical polarizations. The curves are identified as follows:

HH – Response of horizontally polarized port to a horizontally polarized signal.

HV – Response of horizontally polarized port to a vertically polarized signal.

VV – Response of vertically polarized port to a vertically polarized signal.

VH – Response of vertically polarized port to a horizontally polarized signal.

Am-1-11W-CR

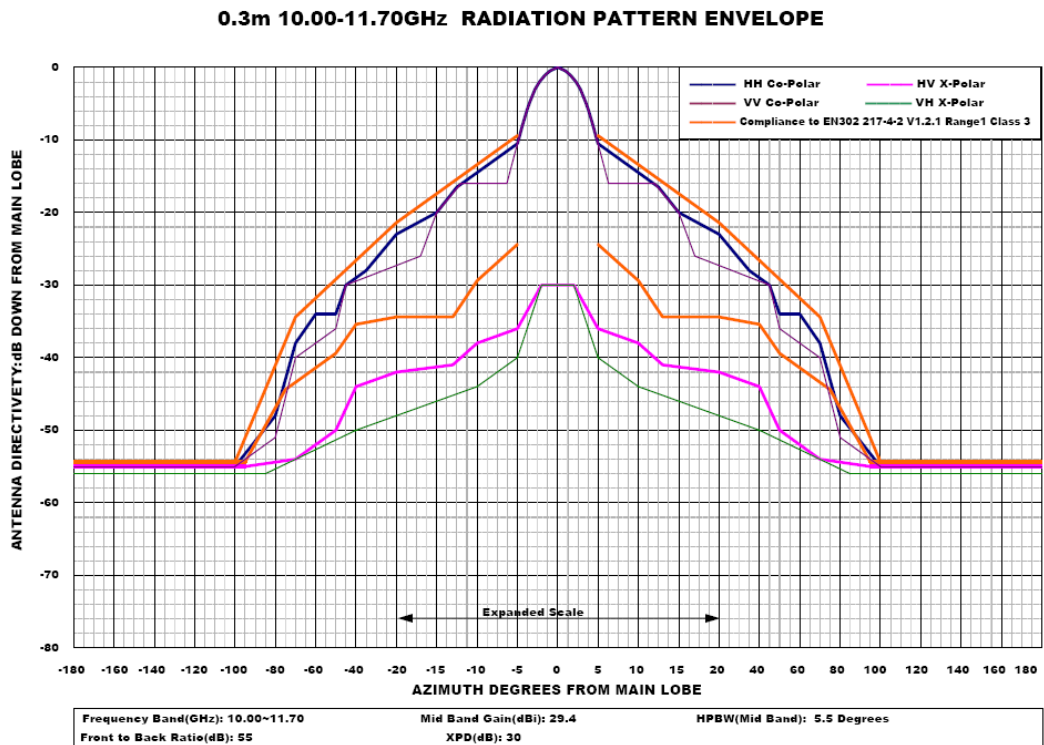

Radiation Pattern Envelope

Co-polar and X-polar response are represented for both horizontal and vertical polarizations. The curves are identified as follows:

HH – Response of horizontally polarized port to a horizontally polarized signal.

HV – Response of horizontally polarized port to a vertically polarized signal.

VV – Response of vertically polarized port to a vertically polarized signal.

VH – Response of vertically polarized port to a horizontally polarized signal.

Am-1-13-CR

0.3m 12.75-13.25GHz RADIATION PATTERN ENVELOPE

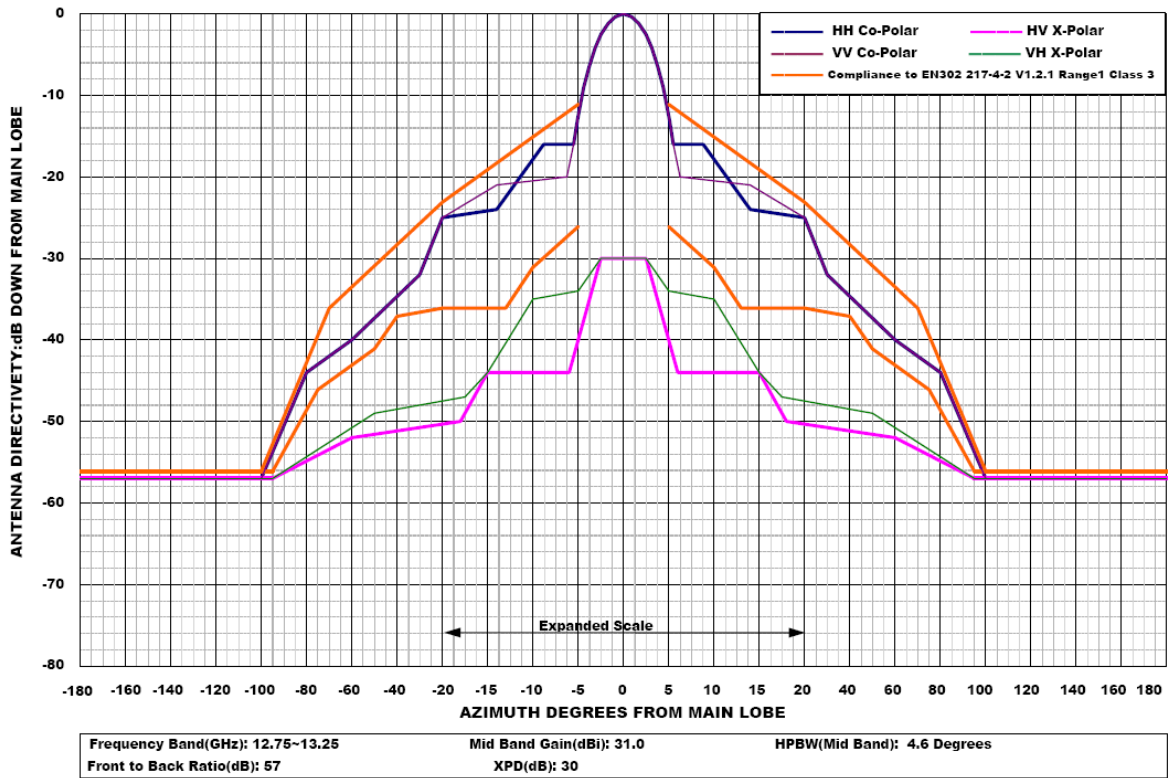

Radiation Pattern Envelope

Co-polar and X-polar response are represented for both horizontal and vertical polarizations. The curves are identified as follows:

HH – Response of horizontally polarized port to a horizontally polarized signal.

HV – Response of horizontally polarized port to a vertically polarized signal.

VV – Response of vertically polarized port to a vertically polarized signal.

VH – Response of vertically polarized port to a horizontally polarized signal.

Am-1-15-CR

0.3m 14.4-15.35GHz RADIATION PATTERN ENVELOPE

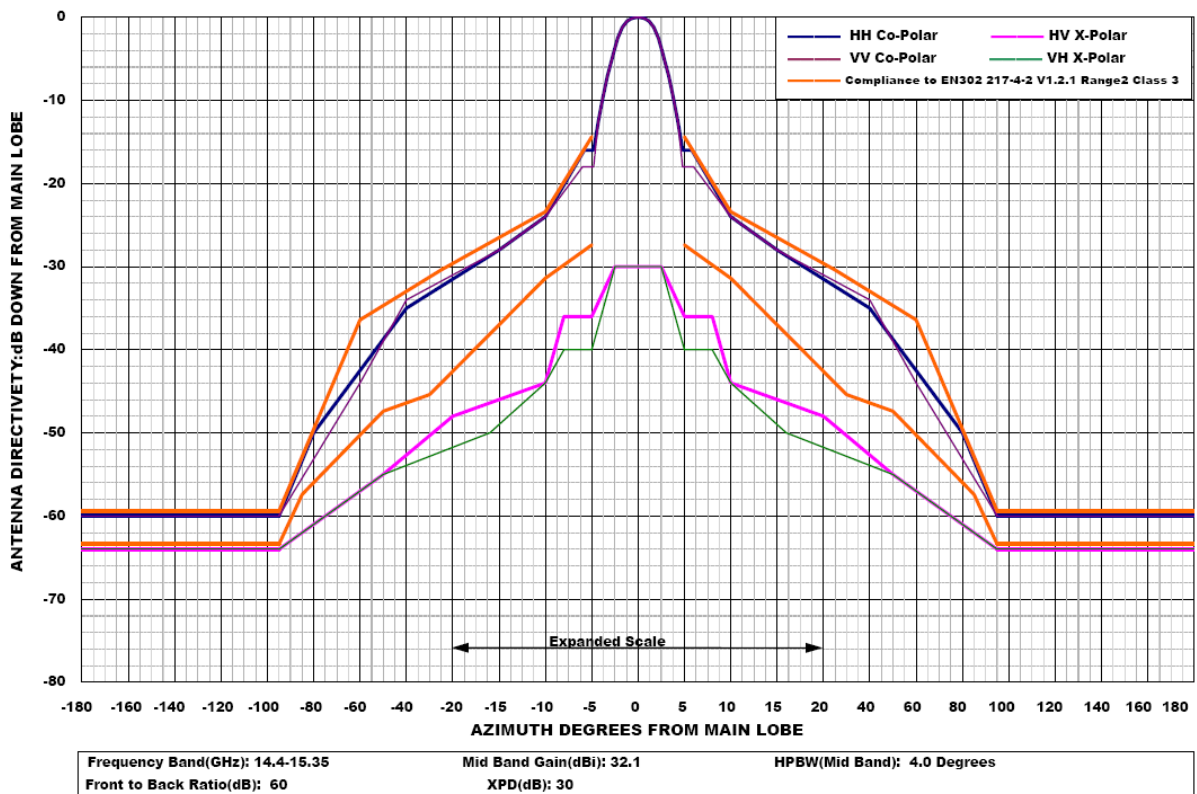

Radiation Pattern Envelope

Co-polar and X-polar response are represented for both horizontal and vertical polarizations. The curves are identified as follows:

HH – Response of horizontally polarized port to a horizontally polarized signal.

HV – Response of horizontally polarized port to a vertically polarized signal.

VV – Response of vertically polarized port to a vertically polarized signal.

VH – Response of vertically polarized port to a horizontally polarized signal.

Am-1-18-CR

0.3m 17.70-19.70GHz RADIATION PATTERN ENVELOPE

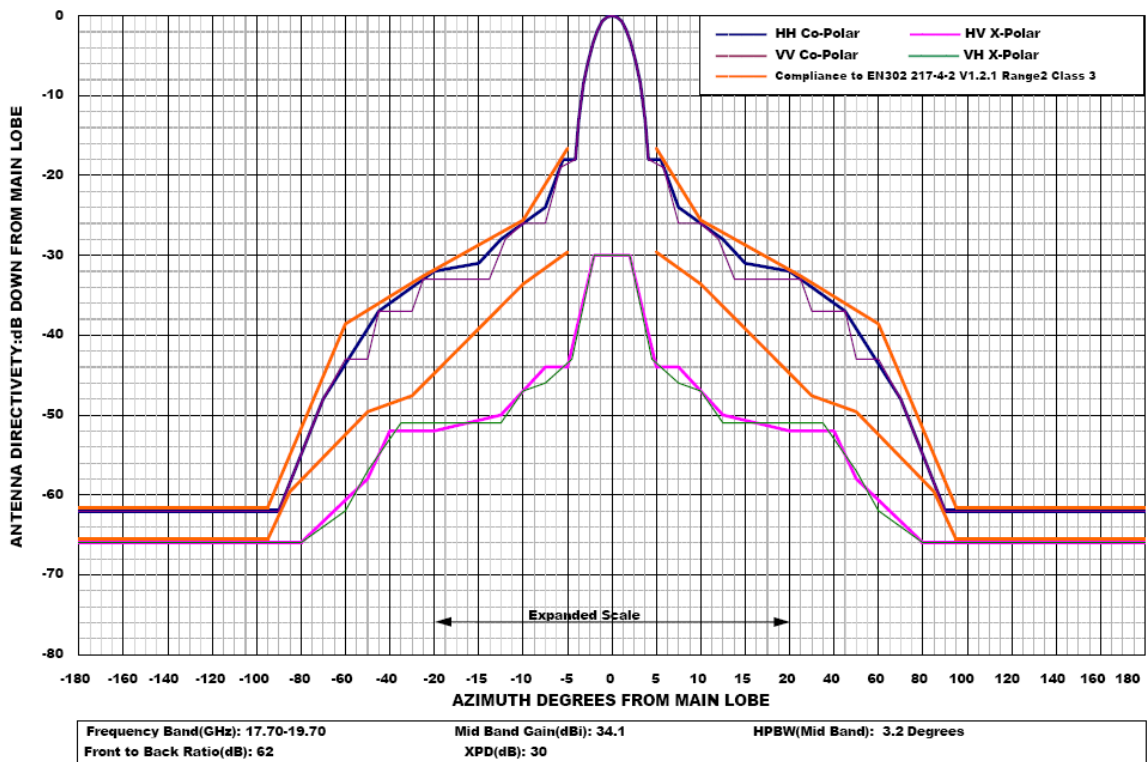

Radiation Pattern Envelope

Co-polar and X-polar response are represented for both horizontal and vertical polarizations. The curves are identified as follows:

HH – Response of horizontally polarized port to a horizontally polarized signal.

HV – Response of horizontally polarized port to a vertically polarized signal.

VV – Response of vertically polarized port to a vertically polarized signal.

VH – Response of vertically polarized port to a horizontally polarized signal.

Am-1-23-CR

0.3m 21.20-23.60GHz RADIATION PATTERN ENVELOPE

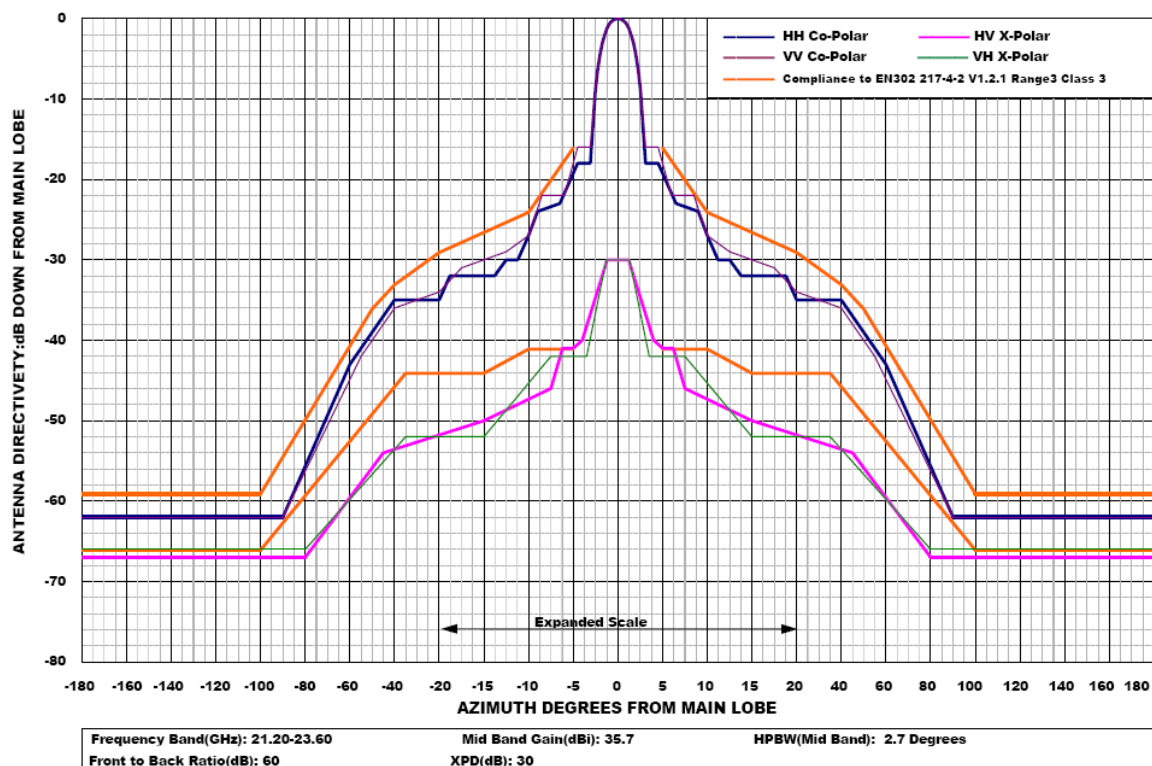

Radiation Pattern Envelope

Co-polar and X-polar response are represented for both horizontal and vertical polarizations. The curves are identified as follows:

HH – Response of horizontally polarized port to a horizontally polarized signal.

HV – Response of horizontally polarized port to a vertically polarized signal.

VV – Response of vertically polarized port to a vertically polarized signal.

VH – Response of vertically polarized port to a horizontally polarized signal.

Am-1-26-CR

0.3m 24.25-26.50GHz RADIATION PATTERN ENVELOPE

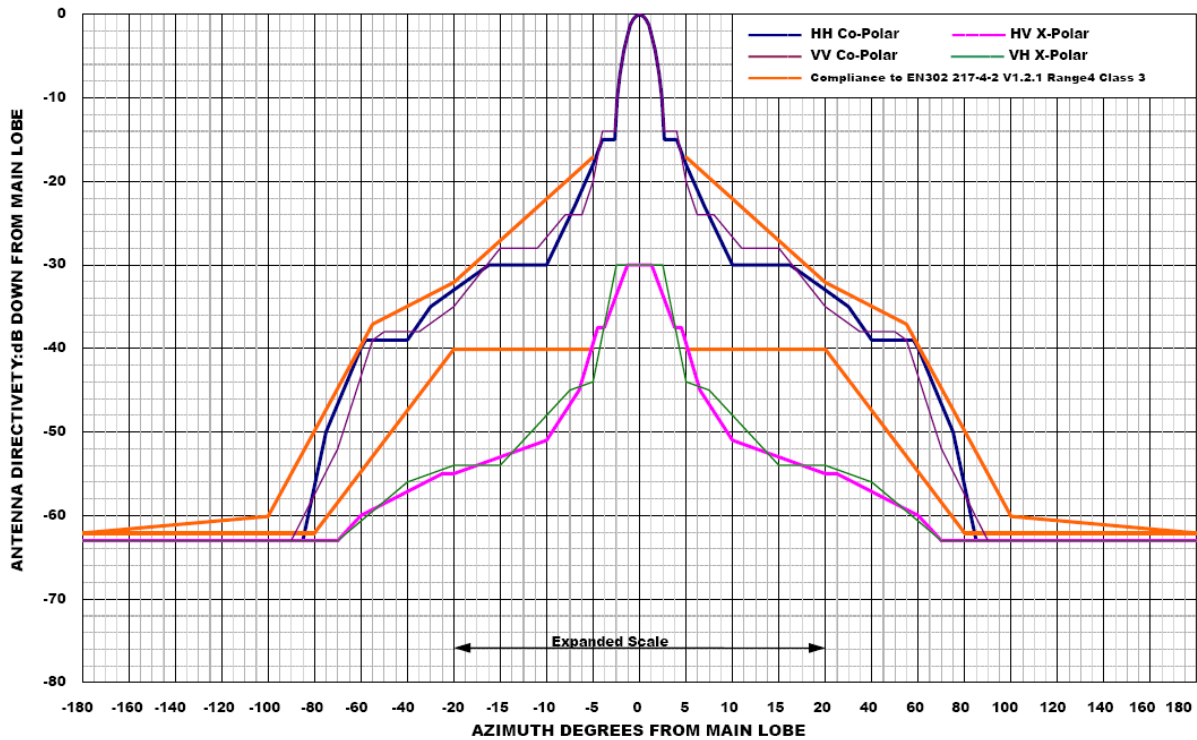

Frequency Band(GHz): 24.25-26.50	Mid Band Gain(dBi): 36.8	HPBW(Mid Band): 2.4 Degrees
Front to Back Ratio(dB): 63	XPD(dB): 30	

Radiation Pattern Envelope

Co-polar and X-polar response are represented for both horizontal and vertical polarizations. The curves are identified as follows:

HH – Response of horizontally polarized port to a horizontally polarized signal.

HV – Response of horizontally polarized port to a vertically polarized signal.

VV – Response of vertically polarized port to a vertically polarized signal.

VH – Response of vertically polarized port to a horizontally polarized signal.

Am-1-28-CR

0.3m 27.50-29.50GHz RADIATION PATTERN ENVELOPE

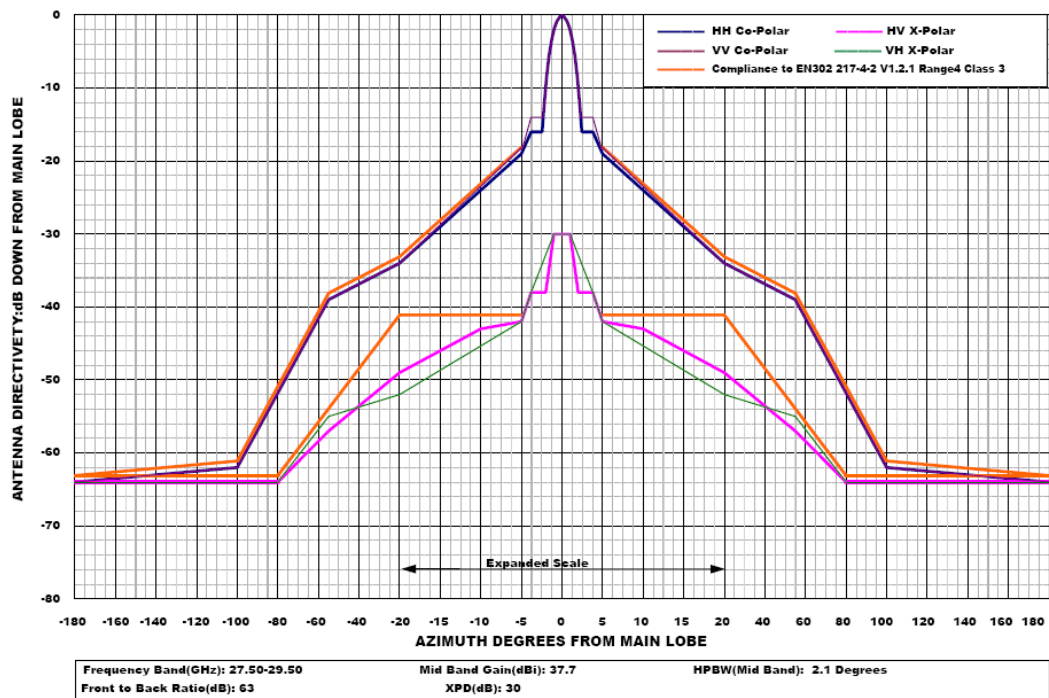

Radiation Pattern Envelope

Co-polar and X-polar response are represented for both horizontal and vertical polarizations. The curves are identified as follows:

HH – Response of horizontally polarized port to a horizontally polarized signal.

HV – Response of horizontally polarized port to a vertically polarized signal.

VV – Response of vertically polarized port to a vertically polarized signal.

VH – Response of vertically polarized port to a horizontally polarized signal.

Am-1-32-CR

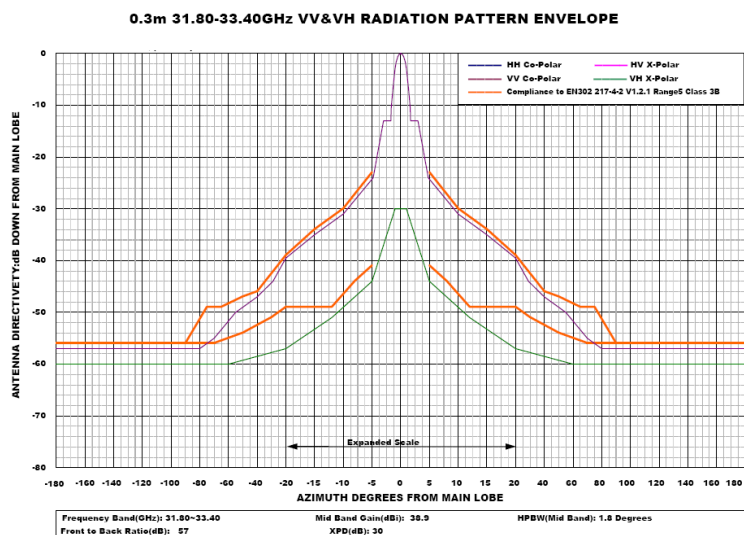

Radiation Pattern Envelope

Co-polar and X-polar response are represented for both horizontal and vertical polarizations. The curves are identified as follows:

HH – Response of horizontally polarized port to a horizontally polarized signal.

HV – Response of horizontally polarized port to a vertically polarized signal.

VV – Response of vertically polarized port to a vertically polarized signal.

VH – Response of vertically polarized port to a horizontally polarized signal.

Am-1-38-CR

0.3m 37.00-40.00GHz HH&HV RADIATION PATTERN ENVELOPE

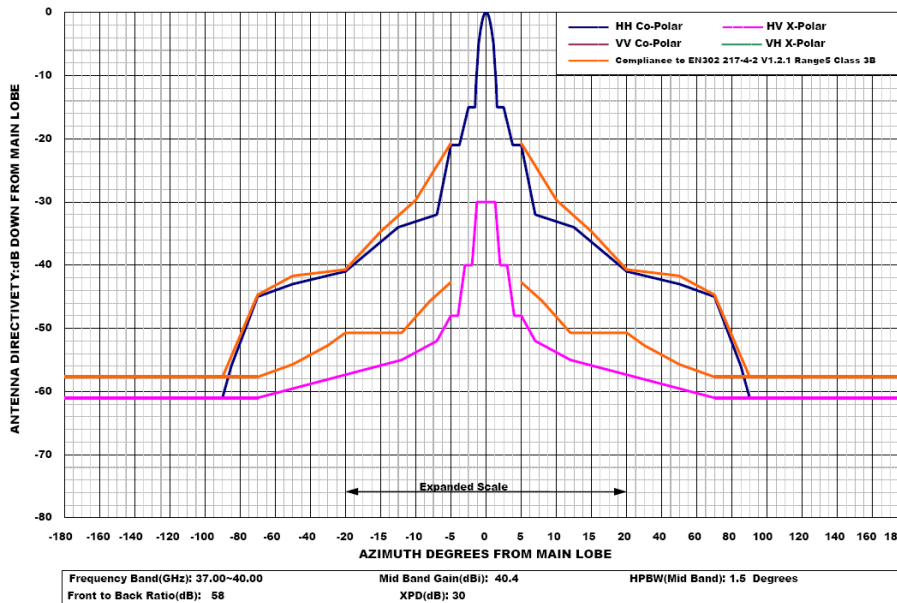

0.3m 37.00-40.00GHz VV&VH RADIATION PATTERN ENVELOPE

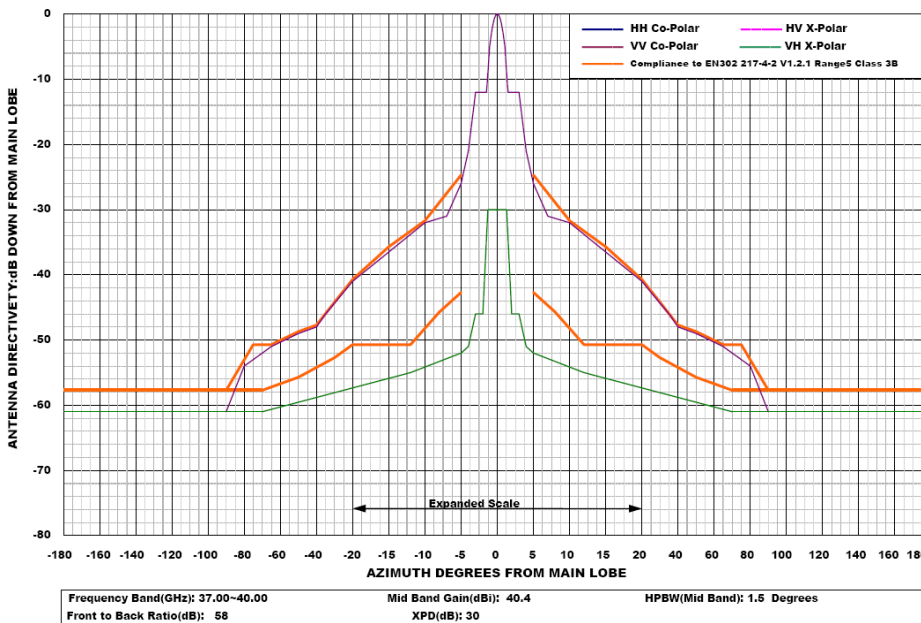

Radiation Pattern Envelope

Co-polar and X-polar response are represented for both horizontal and vertical polarizations. The curves are identified as follows:

HH – Response of horizontally polarized port to a horizontally polarized signal.

HV – Response of horizontally polarized port to a vertically polarized signal.

VV – Response of vertically polarized port to a vertically polarized signal.

VH – Response of vertically polarized port to a horizontally polarized signal.

Am-1-42-CR

0.3m 40.50-43.50GHz HH&HV RADIATION PATTERN ENVELOPE

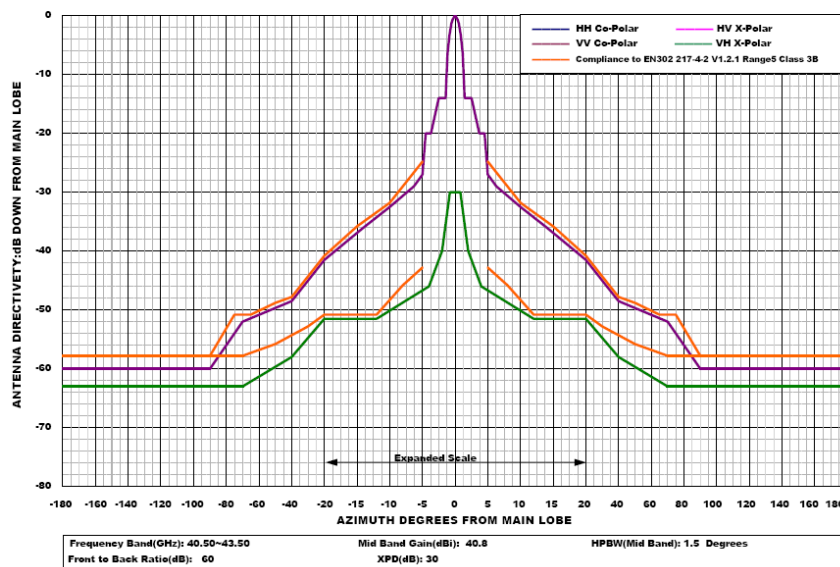

0.3m 40.50-43.50GHz HH&HV RADIATION PATTERN ENVELOPE

